



# Hino 300 Series (EURO 6 Standard Compliant) DENSO Urea Injection System Service Manual

Issued : February 2018

Applicable Vehicle :

Vehicle Name	Release Date
300 Series	December 2017

**© 2018 by DENSO CORPORATION**

All rights reserved. This material may not be reproduced or copied, in whole or in part, without the written permission of DENSO Corporation.

---

## Operation Section

---

### 1. Introduction

1.1	Outline .....	1-1
1.2	Applicable Vehicles .....	1-1

### 2. Urea SCR System

2.1	Outline .....	1-2
2.2	Exhaust Gas Purification Processing .....	1-2

### 3. Urea Injection System Outline

3.1	Outline .....	1-3
3.2	Urea Injection System Operation and Control .....	1-5
3.3	Defrost Heater .....	1-6
3.4	Urea Injector with Cooling Jacket .....	1-7

### 4. Diagnostic Trouble Codes (DTC)

4.1	DTC List .....	1-8
-----	----------------	-----

### 5. External Wiring Diagrams

5.1	Engine ECU .....	1-10
5.2	DCU .....	1-13

# 1. Introduction

## 1.1 Outline

- A DENSO urea injection system has been adopted for the first time for the urea SCR system on the HINO 300 Series released in December 2017. This service manual describes this urea injection system.

## 1.2 Applicable Vehicles

Vehicle Name	Destination Region	Vehicle Model	Engine Type	Engine Displacement	Production Start Date
300 Series	Singapore, Hong Kong	XZU, XKU, Other	N04C	4.009 L	December 2017



## 2. Urea SCR System

### 2.1 Outline

- The urea SCR system is a system developed to reduce the NO<sub>x</sub>\* that is contained in the exhaust gas of diesel engines. This system injects a urea solution into the exhaust gas and reduces NO<sub>x</sub> into non-hazardous nitrogen (N<sub>2</sub>) and water (H<sub>2</sub>O) using a urea SCR catalyst.

\* : Nitrogen oxide (Exhaust gas is mainly composed of Nitric Oxide (NO) and Nitrogen Dioxide (NO<sub>2</sub>))

### 2.2 Exhaust Gas Purification Processing

- The following harmful substances ((1) to (3)) are contained in exhaust gas. Various technologies and systems are being developed that reduce these substances.

	Harmful Substances	Processing Technologies (Selected Examples)
(1)	NO <sub>x</sub>	Urea Selective Catalytic Reduction (SCR)
(2)	CO and HC	DOC (Oxidation Catalyst)
(3)	PM	DPF

- A urea SCR system is a system designed to effectively reduce NO<sub>x</sub>. In principle, this system reduces the NO<sub>x</sub> into nitrogen (N<sub>2</sub>) and water (H<sub>2</sub>O) through the chemical reaction between the ammonia (NH<sub>3</sub>) and NO<sub>x</sub>.

Tanks filled with a urea solution are used due to the inherent danger of mounting sources of ammonia on vehicles. This urea solution is then injected into the exhaust gas to generate ammonia through thermal decomposition and hydrolysis due to the high temperature (exhaust heat).

- The NO<sub>x</sub> contained in exhaust gas with urea injected reacts with the ammonia on the urea SCR catalyst and is reduced to nitrogen (N<sub>2</sub>) and water (H<sub>2</sub>O). The general reactions are shown in the following three formulas.

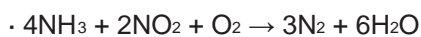
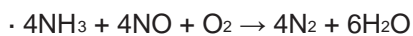

NO and NO<sub>2</sub> are reduced to N<sub>2</sub> and H<sub>2</sub>O

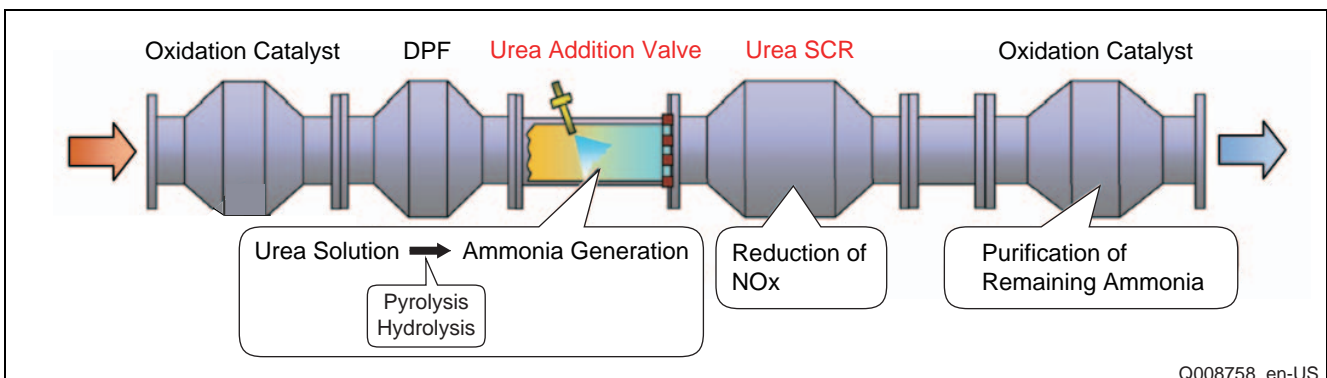

### 3. Urea Injection System Outline

#### 3.1 Outline

- The urea injection system is the primary system that comprises the urea SCR system. This is the first time a DENSO manufactured system has been used.

System	Component	Manufacturer	DENSO Part Number
Engine Management System	Engine	HINO	—
	ECU	DENSO	275700-962# 275700-963#
Urea SCR System	Urea Injector with Cooling Jacket	DENSO	297350-001#
	DCU	DENSO	276000-007#
	Urea Tank Module	HINO	—
	Urea Solution Pipe	HINO	—
	Catalyst (DOC/DPF/SCR/ASC)	HINO	—
	NOx Sensor	DENSO	226500-190#
	Exhaust Gas Temperature Sensor	DENSO	265700-225#

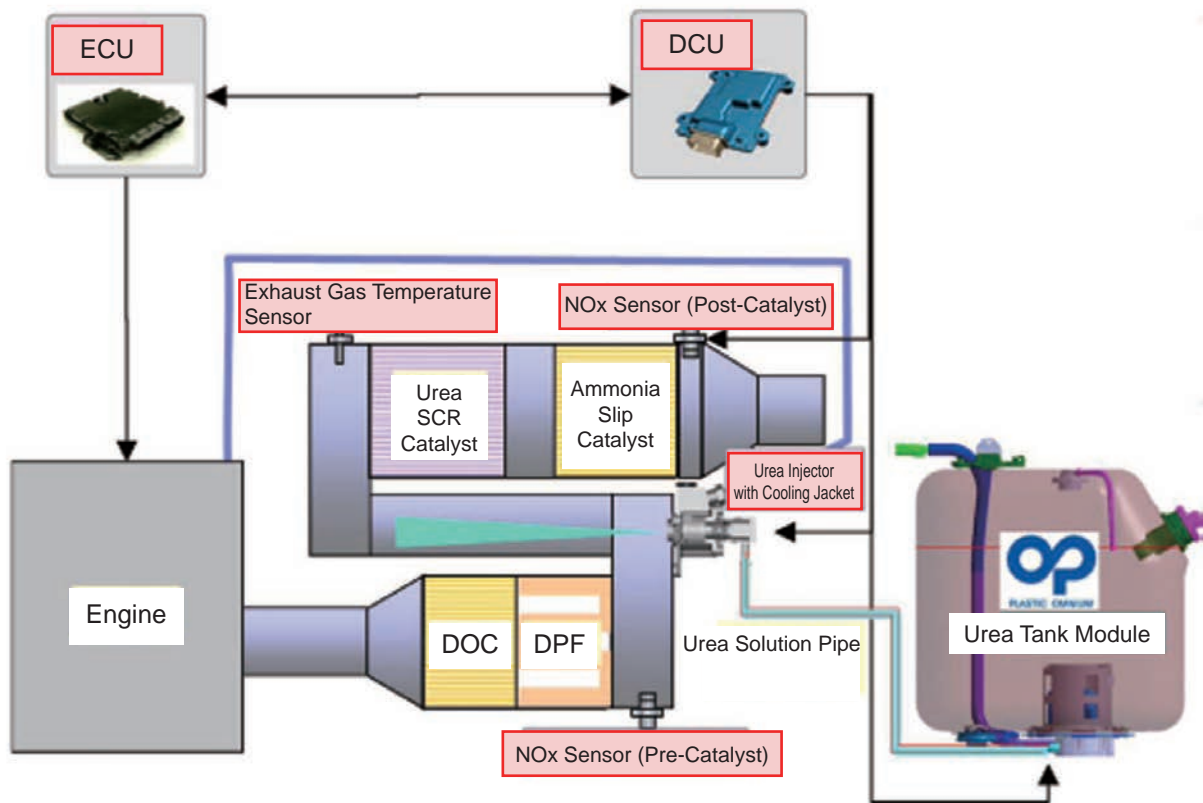

- Control is performed for the following processes ((1) to (5)) based on commands received from the ECU and DCU.

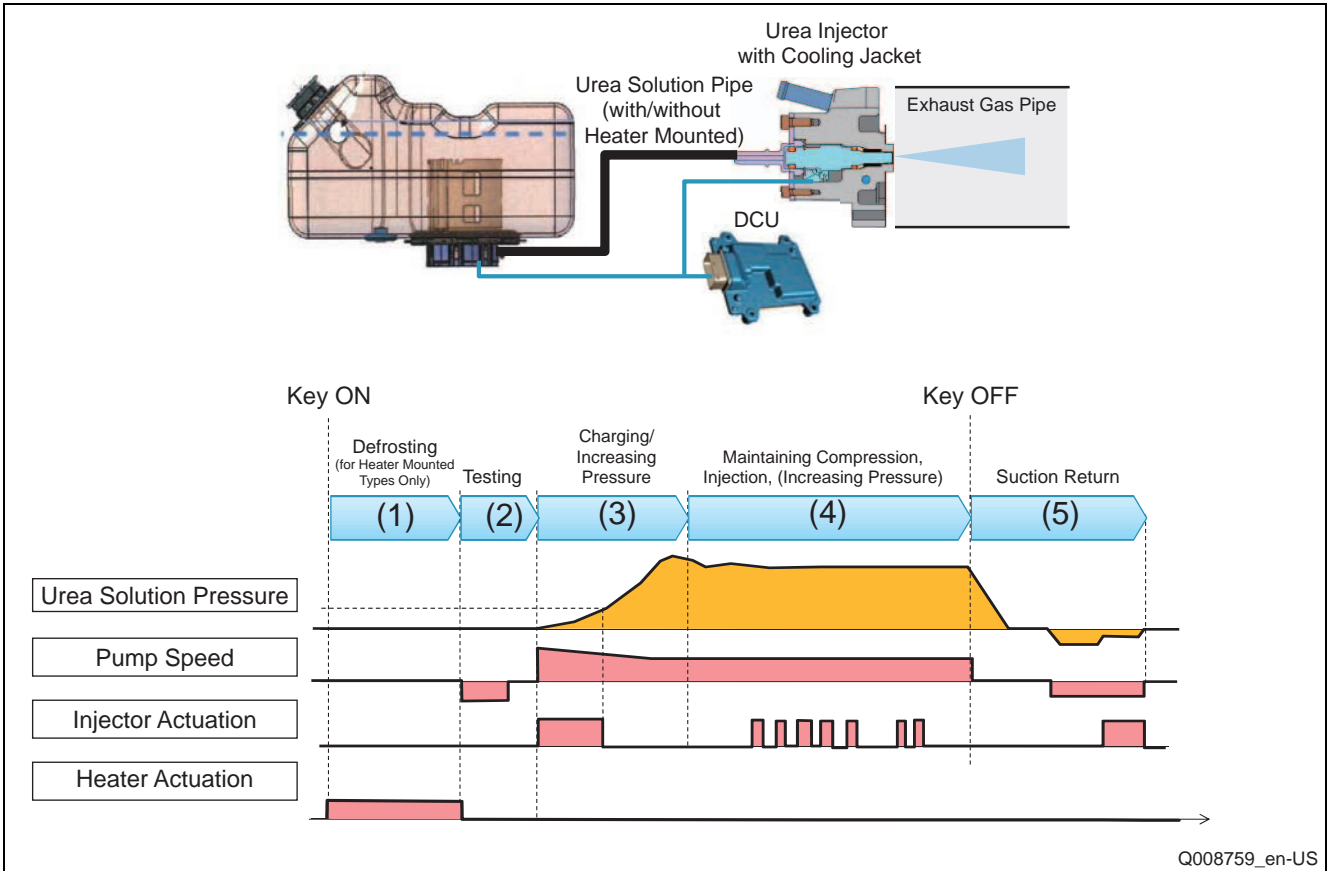

- Urea solution in the tank is injected into the exhaust pipe through the following path.

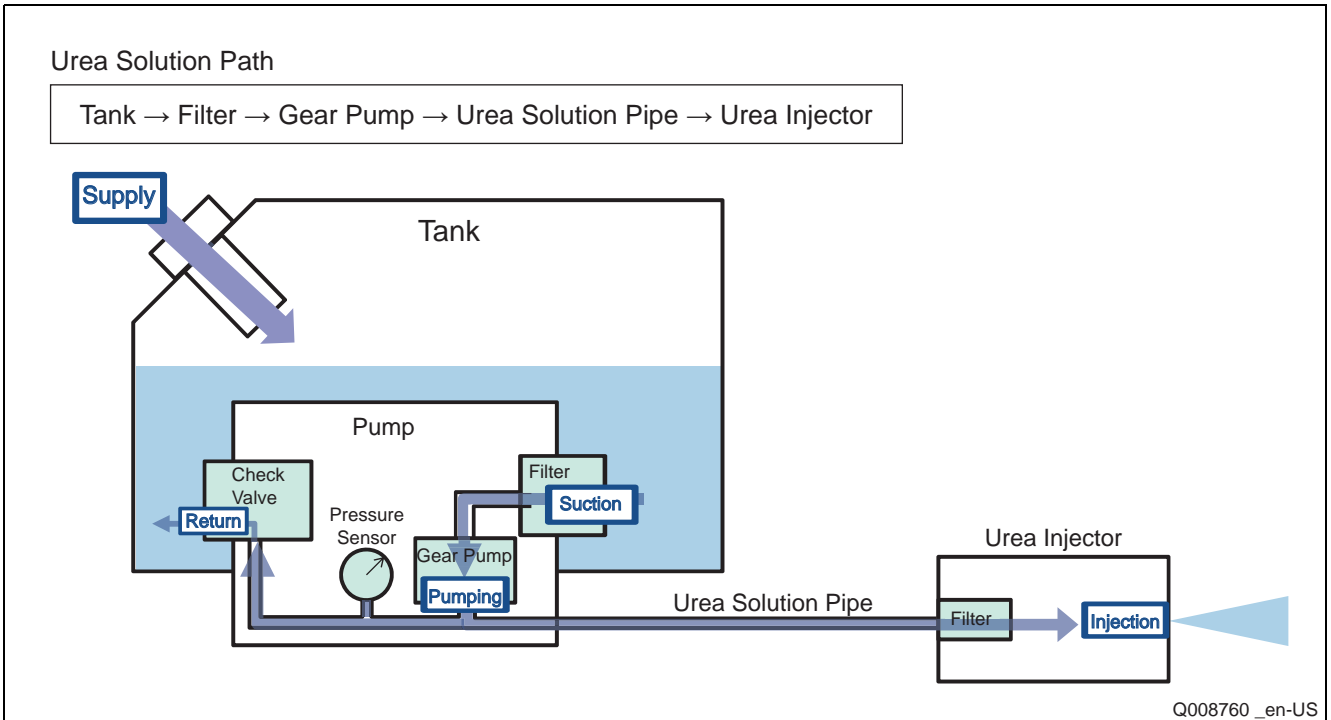

### 3.2 Urea Injection System Operation and Control

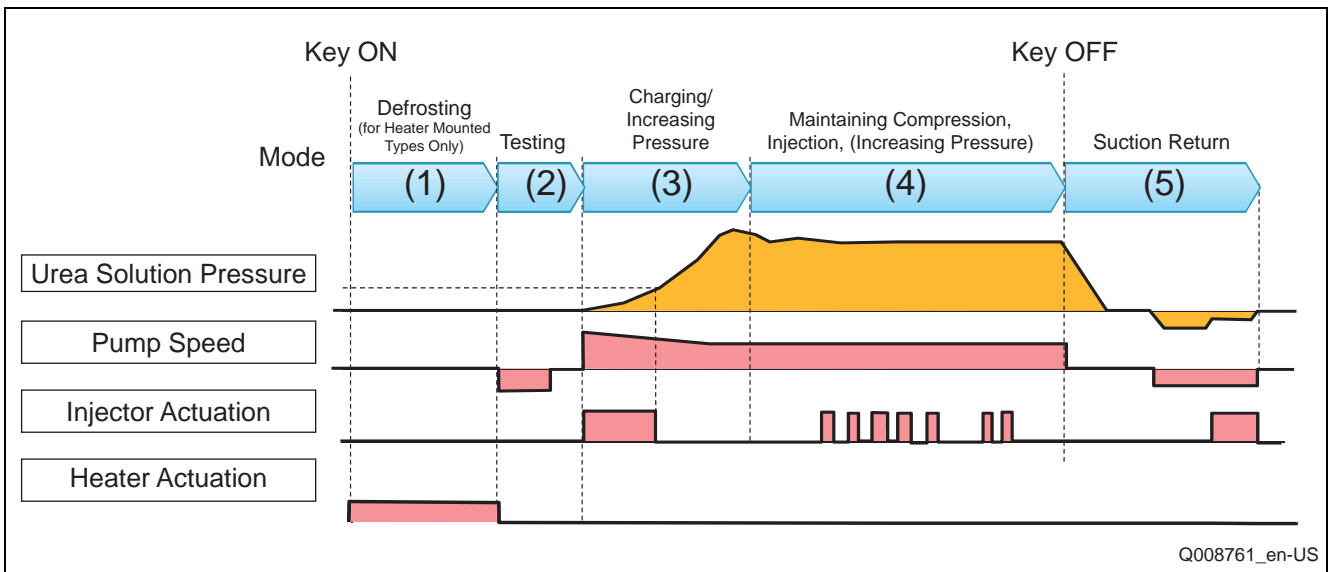

**(1) Defrosting (Heater Mounted Types Only)**

- Defrosts the urea solution by energizing the heater when the urea solution is frozen to make injection of the urea solution possible.

**(2) Testing**

- Judges whether the pump is operating normally before pumping.

**(3)Charging and Increasing Pressure**

- Urea solution is pumped using the pump in order to fill the urea solution pump circuit. The urea injector is opened at the same time, discharging the air in the pipe and urea injector.
- Pumps urea solution using the pump and pressurizes up to the target of five bars.

**(4) Maintaining Pressure/Injection**

- Maintains a urea solution pressure of five bars and controls the pump speed according to the pressure decreases and increases caused by the injection of urea solution and other factors.
- Urea solution is injected at the injection quantity requested by the ECU.

**(5) Retraction**

- In order to prevent parts from becoming broken or damaged due to the expansion of frozen urea solution, urea solution in the urea injector and urea solution piping is drawn back into the tank by operating the pump in reverse for a specified amount of time after the engine is stopped.

**Mode Transition Conditions**

Mode	Transition Condition
Testing	A certain period of time elapses after the key is turned ON and the engine speed is at the idle speed or higher.
Charging	After testing has been completed normally, the exhaust temperature is at or above the specified temperature, the engine speed is higher than the idle speed, the tank is not set to defrost mode, and there is no close stick error detected the previous injection operation.
Increasing Pressure	After charging has completed normally. Additionally, when a pressure drop occurs while in pressure retaining mode.
Maintaining Pressure	After charging and pressure rise mode has completed normally.
Urea Solution Injection	When an injection quantity request is received from the ECU while in pressure retaining mode.
Return Suction	When the key turned OFF (Only when charged).



### 3.3 Defrost Heater

- There are two types of specifications (with or without a heater) depending on the destination country.
  - \* The Singapore and Hong Kong specifications do not include a heater
- Line heaters are additionally provided that function as described below in (1) through (3) for heat mounted type specifications.
  - (Heaters (1) and (2) below function for standard types [without an additional heater mounted])
- The pump heater uses the motor as the heat source so no actual heater is installed.

Heater Type	Heat Source	Defrost Range	Heater Operation Command Source	Operation Timing
(1) Tank Heater	Silicon Heater	Pump Area	ECU	When command received from ECU
(2) Pump Heater	Motor Coil	Gear Pump Area	DCU	Operation time determined according to urea solution temperature
(3) Line Heater	Hot-Wire	Inside urea solution pipe	ECU	When command received from ECU

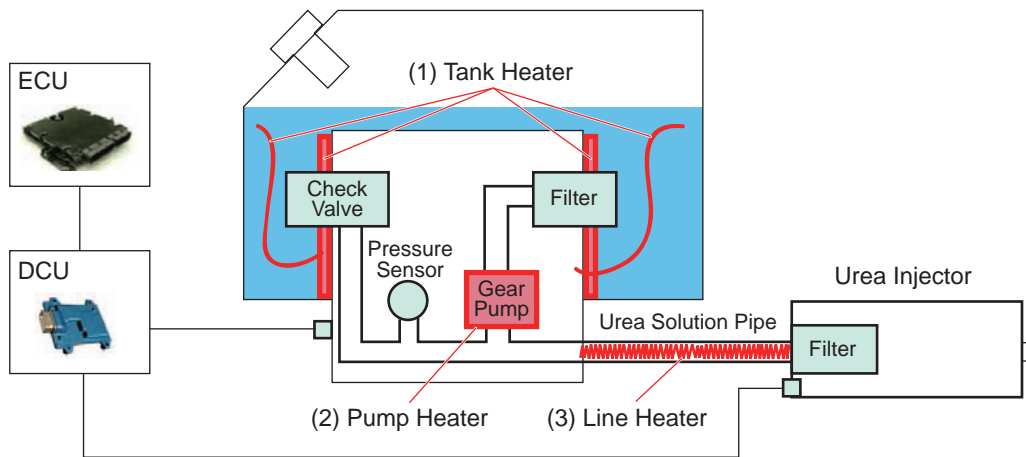

Q008754\_en-US

### 3.4 Urea Injector with Cooling Jacket

**Features**

- A cooling jacket is placed around the injector and circulates coolant, allowing the injector to operate in high temperature environments.

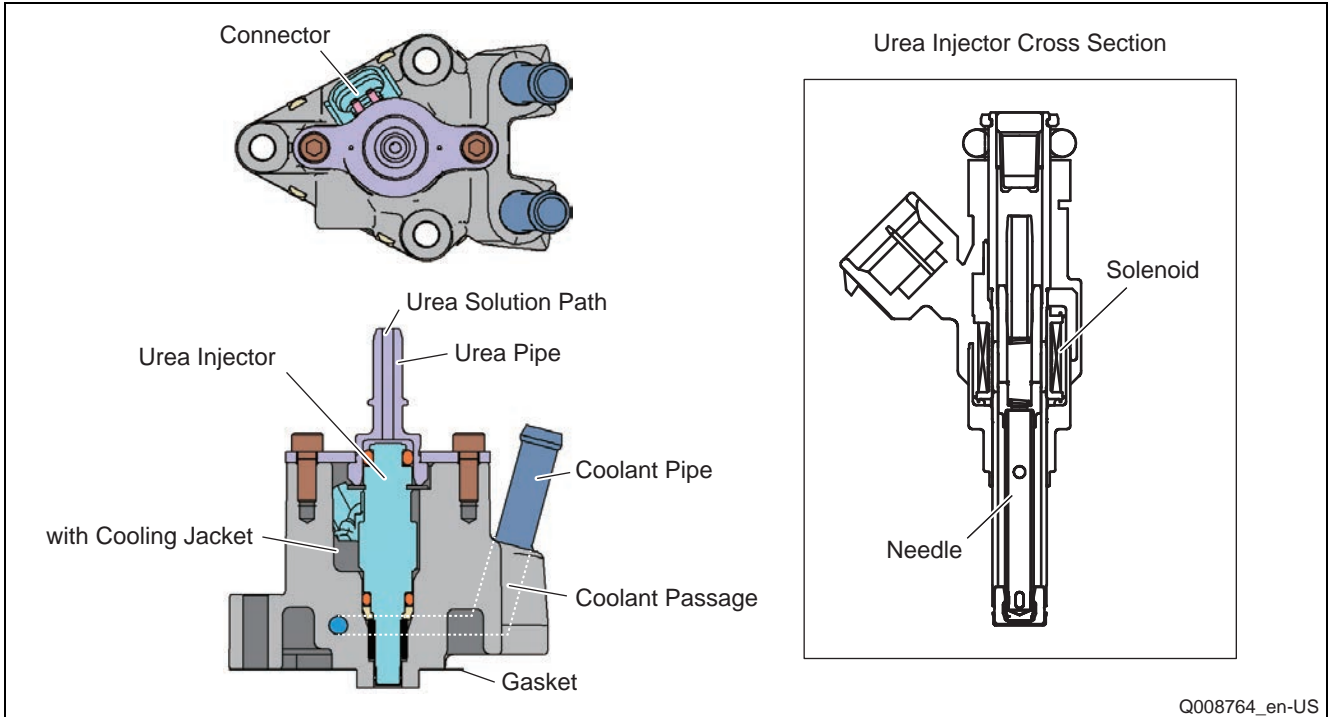

**Operation**

- When injection is being performed, the needle is pulled up by the energizing of solenoid, and the urea solution is injected through the spray holes.

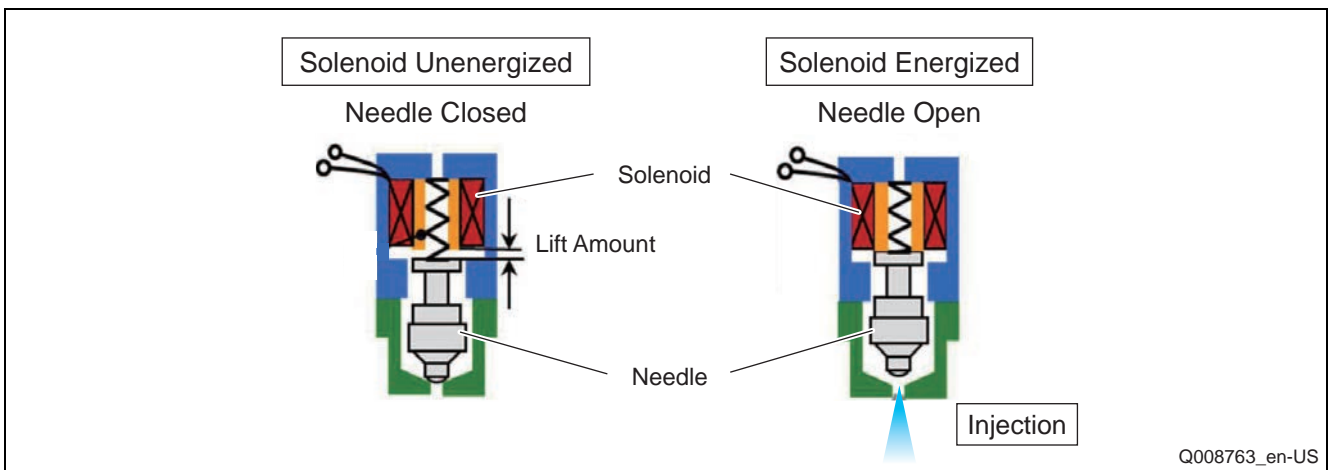

## 4. Diagnostic Trouble Codes (DTC)

### 4.1 DTC List

Pcode	Diagnosis item	Symptom
P0000	Upstream NOx sensor disconnection	InNoxSnsrCanOpen
P0000	Downstream NOx sensor disconnection	OutNoxSnsrCanOpen
P0000	Urea Injector Consumption High Error	UrCnsHi
P0000	Urea Pump Performance Error(Highspeed)	PmpPrfmncHiSpd
P0071	Dcu Ambient Temperature Plausibility Error	DcuAmbTImps
P0072	Ambient Temperature Sensor Lo Error	DcuAmbTLo
P0073	Ambient Temperature Sensor Hi Error	DcuAmbTHi
P0562	Battery Voltage Lo Error	BattULo
P0563	Battery Voltage Hi Error	BattUHi
P0605	DCU Flash ROM Error	DcuFlashRom
P0642	Sensor Vcc1 Lo Error	SnsrVccLo
P0643	Sensor Vcc1 Hi Error	SnsrVccHi
P0652	Sensor Vcc2 Lo Error	SnsrVcc2Lo
P0653	Sensor Vcc2 Hi Error	SnsrVcc2Hi
P202E	Urea Injector Close Stick Error	InjStuckCls
P202E	Urea Injector Open Stick Error	InjStuckOpen
P203B	Urea Level Plausibility Error	UrLvllmp
P203B	Urea Level Sensor Stuck Error	UrLvIStuck
P203B	Urea Level Sensor Offset Error	UrLvIOffs
P203B	Urea Level Sensor Float Too High Error	UrLvIFloatHi
P203C	Urea Level Sensor Lo Error	UrLvILO
P203D	Urea Level Sensor Hi Error	UrLvIHi
P2043	Urea Quality Temperature Sensor Plausibility Error	UrT2Imps
P2044	Urea Quality Temperature Sensor Lo Error	UrT2Lo
P2045	Urea Quality Temperature Sensor Hi Error	UrT2Hi
P2045	Urea Quality Temperature Sensor Open Error	UrT2Open
P2048	Urea Injector Short to Ground or Open Load	UrInjShoGnd
P2049	Urea Injector Short to Battery	UrInjShoBatt
P204B	Urea Pressure Plausibility Error	UrPOffs
P204B	Urea Pressure Stuck Error	UrPStuck
P204C	Urea Pressure Sensor Lo Error	UrPLO
P204D	Urea Pressure Sensor Hi Error	UrPHi
P205B	Urea Temperature Plausibility Error	UrTImps
P205C	Urea Temperature Sensor Lo Error	UrTLO

Pcode	Diagnosis item	Symptom
P205D	Urea Temperature Sensor Hi Error	UrTHi
P206A	Urea Quality Sensor General Electric Error	UrQlyElec
P206A	Urea Quality Temperature Sensor General Electric Error	UrT2Elec
P206B	Urea Quality Sensor Plausibility Error	UrQlyImps
P206C	Urea Quality Sensor Lo Error	UrQlyLo
P206D	Urea Quality Sensor Hi Error	UrQlyHi
P206D	Urea Quality Sensor Open Error	UrQlyOpen
P208B	Urea Pump Performance Error(feedback)	PmpPrfmncFb
P208B	Urea Pump Performance Error (filling)	PmpPrfmncFillg
P208B	Urea Pump Performance Error (testing)	PmpPrfmncTest
P208C	Urea Pump Motor Short to Ground or Open Load	UrPmpMotShoGnd
P208D	Urea Pump Motor Short to Battery	UrPmpMotShoBatt
P20B9	Urea Tank Heater Open Load	UrTankHtrOpenLoad
P20BA	Urea Tank Heating Performance Error	TkHtgPrfmnc
P20BB	Urea Tank Heater Short to Ground	UrTankHtrShoGnd
P20BC	Urea Tank Heater Short to Battery	UrTankHtrShoBatt
P20BD	Urea Line Heater Open Load	UrLineHtrOpenLoad
P20BF	Urea Line Heater Short to Ground	UrLineHtrShoGnd
P20C0	Urea Line Heater Short to Battery	UrLineHtrShoBatt
P20E8	Urea Pressure Control Low Failure	UrPCtrlLo
P20E9	Urea Pressure Control High Failure	UrPCtrlHi
P20E9	Urea Pressure Over Error	UrPOver
P20F4	Urea Injector Consumption Low Error	UrCnsLo
P2481	Pre Exhaust Temperature Sensor Lo Error	ScrInGasTLo
P2482	Pre Exhaust Temperature Sensor Hi Error	ScrInGasTHi
U0029	CAN1 Bus Off	Can1BusOff
U0038	CAN2 Bus Off	Can2BusOff
U0100	Engine ECU disconnection	EngEcuCanOpen
U02A2	Urea Quality Sensor Disconnection	UrQlySnsrCanOpen

# 5. External Wiring Diagrams

## 5.1 Engine ECU

### (1) Engine ECU External Wiring Diagrams

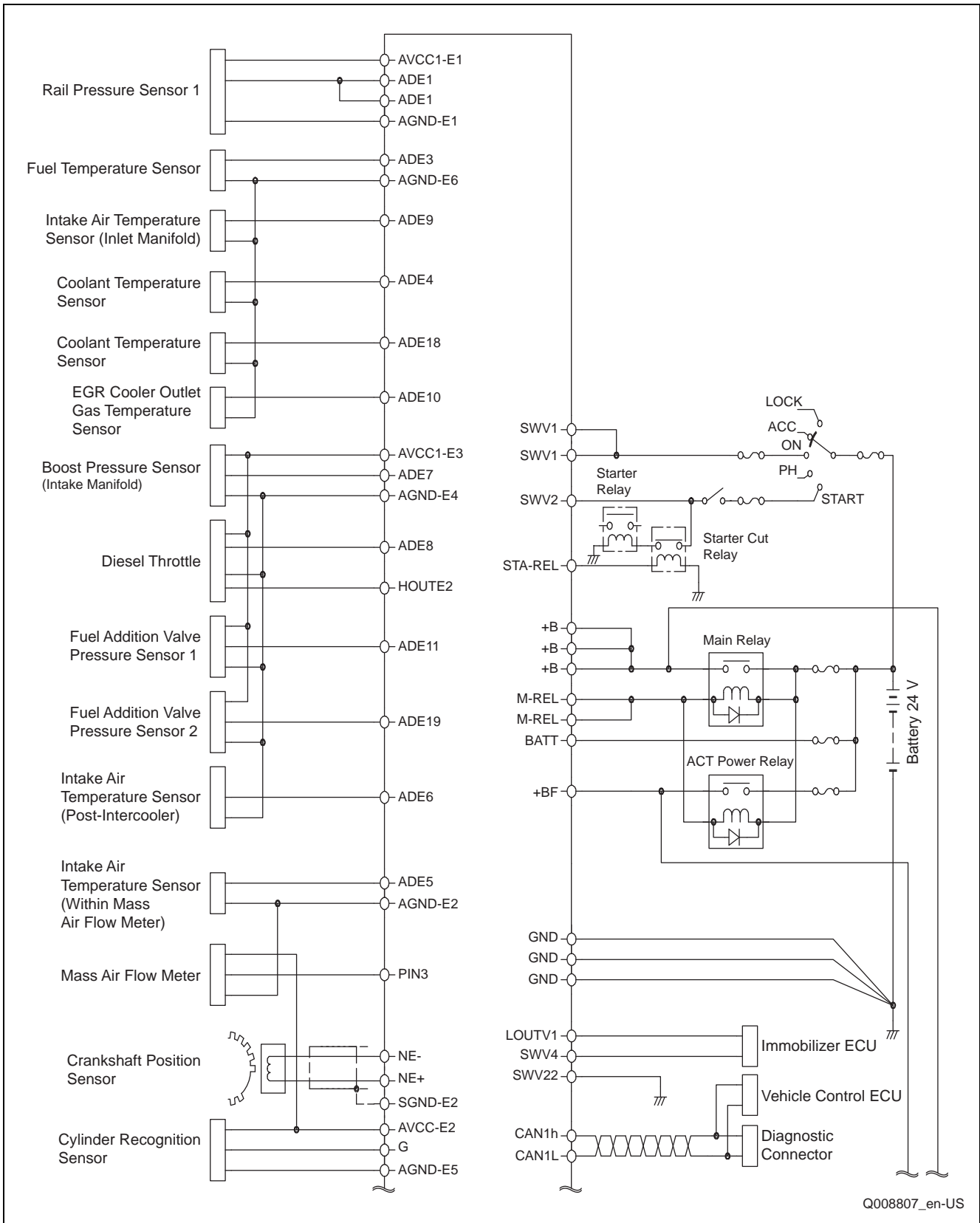

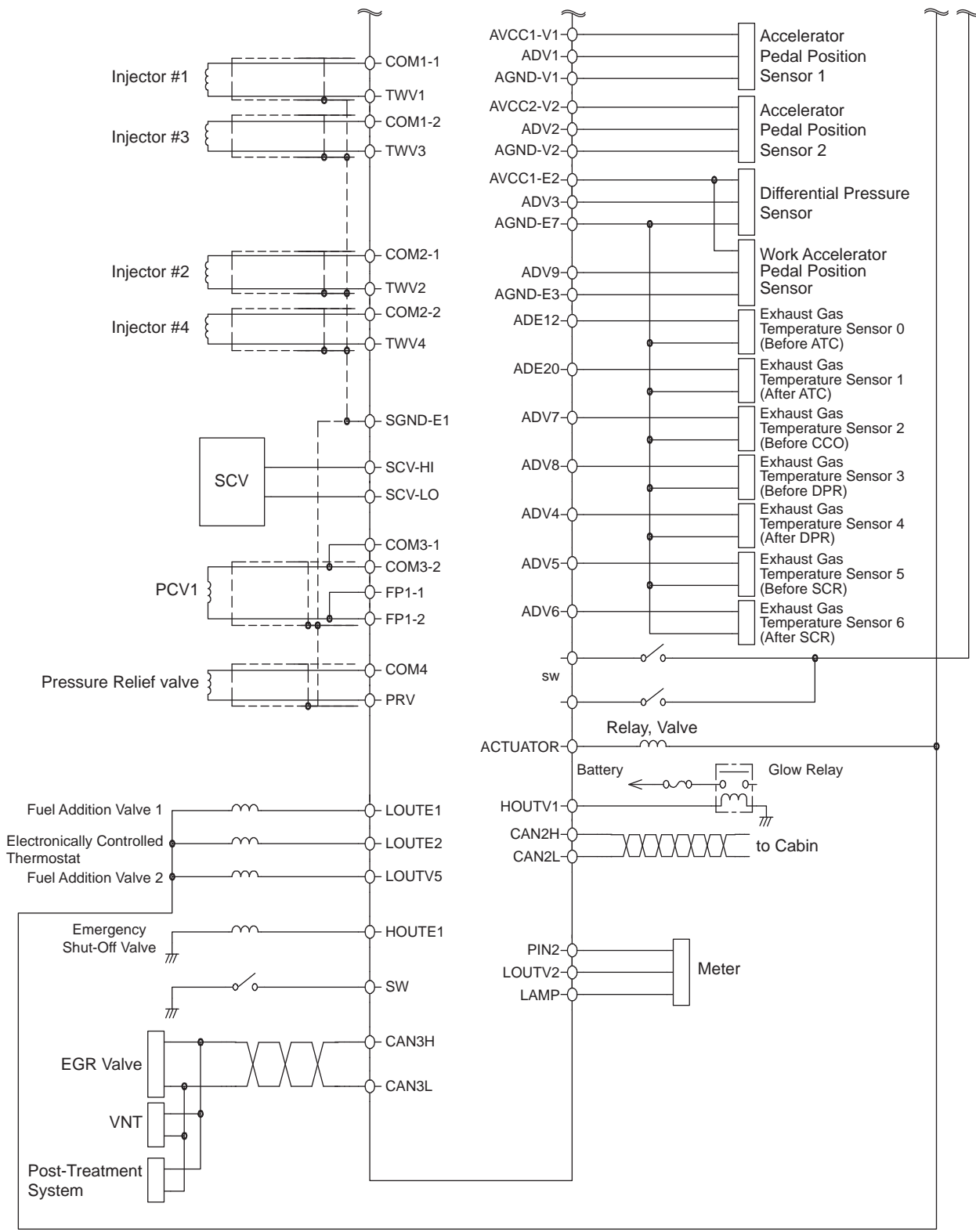

## (2) Engine ECU Connector Diagram

Engine Block (114P)

E001	E002	E003	E004	E005	E006	E007	E008	E009
COM4	FP2	(TWW5)	TWV3	TWV1	/	DCM1+	/	LOUTE1
E010	E011	E012	E013	E014	E015	E016	E017	E018
(TWV6)	COM2-3	COM1-3	COM1-2	COM1-1	/	DCM1-	/	/

E019	E020	E021	E022	E023	E024	E025	E026	E027
TWV4	COM2-2	FP1-1	FP1-2	PRV	/	/	SCV-LO	LOUTE3
E028	E029	E030	E031	E032	E033	E034	E035	E036
TWV2	COM2-1	COM3-1	COM3-2	COM3-3	HOUTE1	/	SCV-HI	LOUTE2

E037	E038	E039	E040	E041	E042	E043	E044	E045	E046	E047	E048	E049
/	/	/	ADE1-1	ADE1-2	ADE3	/	ADE4	ADE7	ADE8	ADE5	ADE6	ADE11
E050	E051	E052	E053	E054	E055	E056	E057	E058	E059	E060	E061	E062
/	/	/	ADE2-1	ADE2-2	ADE10	/	ADE9	ADE12	ADE19	(ADE14)	(ADE15)	(ADE16)
E063	E064	E065	E066	E067	E068	E069	E070	E071	E072	E073	E074	E075
/	/	/	/	SWE1	SWE2	/	AVCC1-E1	ADE17	ADE18	ADE13	ADE20	AVCC2-E1
E076	E077	E078	E079	E080	E081	E082	E083	E084	E085	E086	E087	E088
SGND-E1	AVCC1-E2	AVCC1-E3	AVCC2-E2	SWE3	SWE4	/	AGND-E1	/	/	/	/	AGND-E2
E089	E090	E091	E092	E093	E094	E095	E096	E097	E098	E099	E100	E101
SGND-E2	AGND-E3	AGND-E4	AGND-E5	SWE5	/	/	AGND-E6	NE+	(LOUTE8)	(LOUTE8)	PIN5	CAN3H
E102	E103	E104	E105	E106	E107	E108	E109	E110	E111	E112	E113	E114
/	/	HOUTE2	/	/	/	G	AGND-E7	NE-	/	/	/	CAN3L

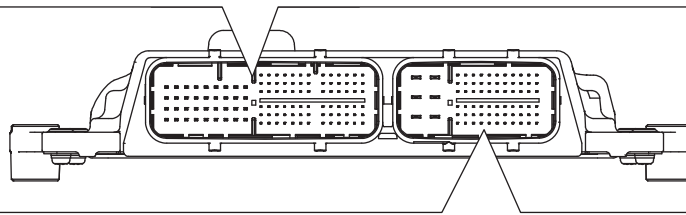

Vehicle Block (72P)

V001	V002
+B	GND

V003	V004
+B	GND

V005	V006
+B	GND

V007	V008	V009	V010	V011	V012	V013	V014	V015	V016	V017
ADV1	ADV3	ADV2	ADV4	ADV5	SWV1-1	SWV1-2	SWV2	LOUTV7	LOUTV5-1	LOUTV5-2
V018	V019	V020	V021	V022	V023	V024	V025	V026	V027	V028
ADV6	ADV7	ADV8	ADV9	ADV10	SWV3	SWV4	SWV5	LOUTV1	LOUTV2	(LOUTV3)
V029	V030	V031	V032	V033	V034	V035	V036	V037	V038	V039
AVCC1-V1	AVCC2-V1	AGND-V1	AGND-V2	SWV6	SWV7	SWV8	SWV9	M-REL1	M-REL2	STA-REL
V040	V041	V042	V043	V044	V045	V046	V047	V048	V049	V050
CAN1H	PIN3	SWV10	SWV11	SWV12	SWV13	SWV14	LOUTV6-1	LOUTV6-2	/	LOUTV9
V051	V052	V053	V054	V055	V056	V057	V058	V059	V060	V061
CAN1L	PIN2	(PIN4)	SWV15	SWV16	SWV17	SWV18	SWV19	LOUTV10	LOUTV11	+BF
V062	V063	V064	V065	V066	V067	V068	V069	V070	V071	V072
CAN2L	CAN2H	BATT	SWV20	SWV21	SWV22	SWV23	HOUTV1-1	HOUTV1-2	LOUTV4	CASE-GND

## 5.2 DCU

### (1) DCU External Wiring Diagrams

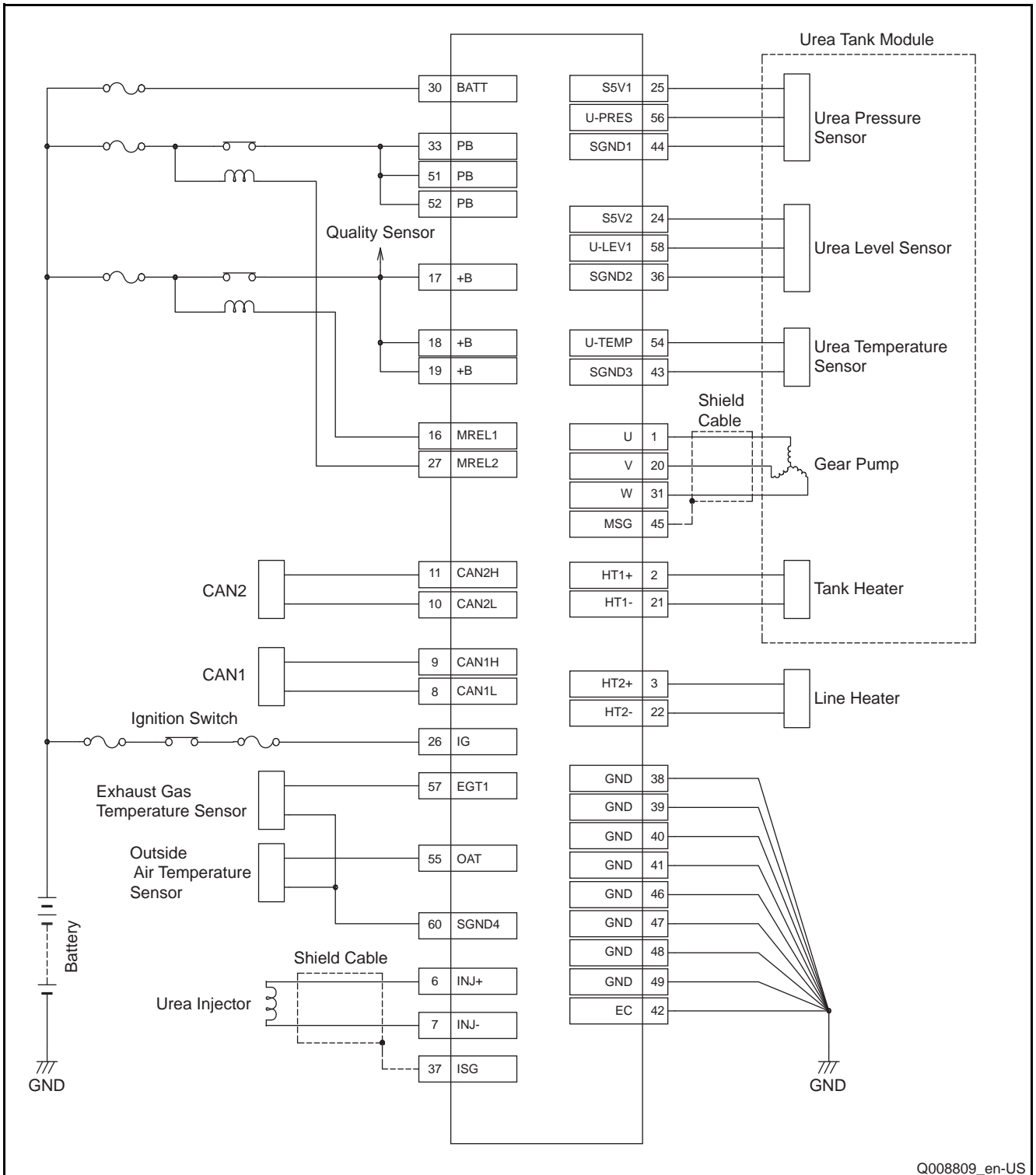



(2) ECU Connector Diagram

